

INCOMING LINE POWER Disconnect Located External to the Enclosure
480VAC, 50Hz, 200A

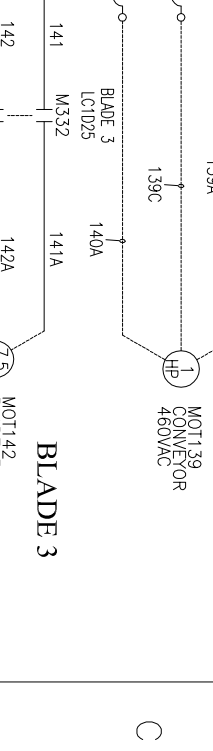

DRIVES POWER

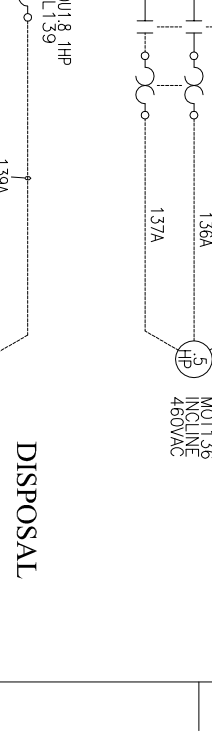
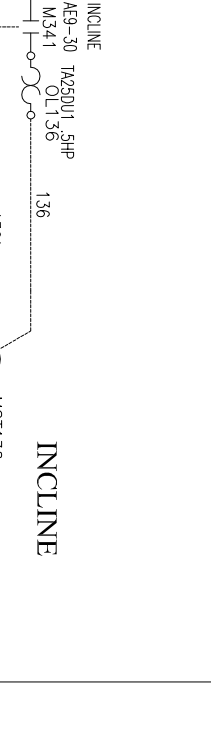
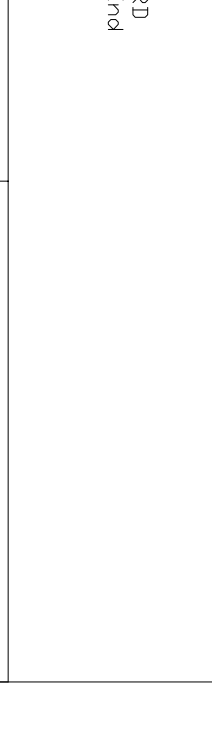
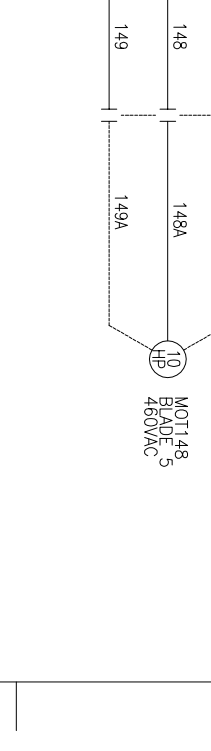
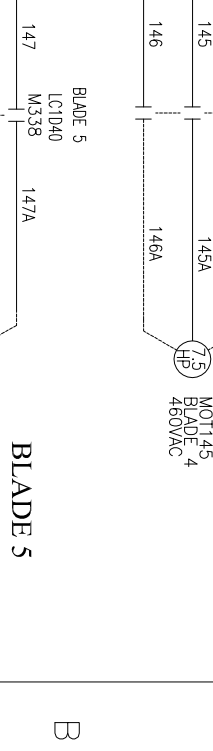
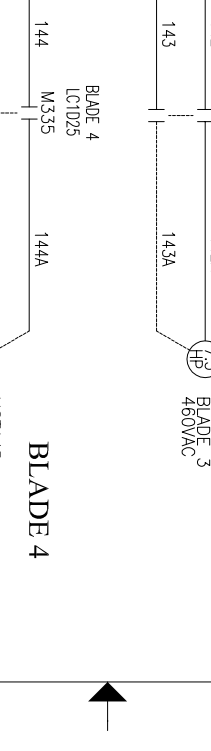
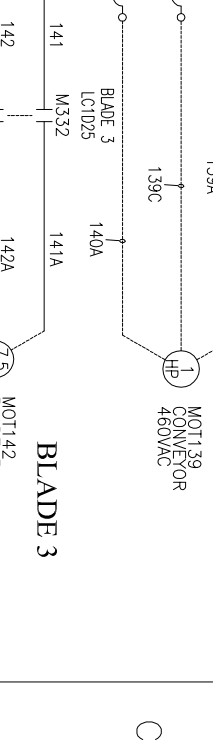
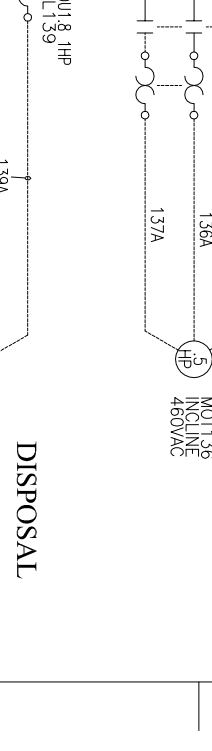
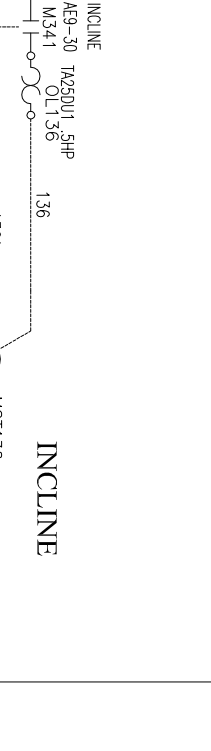
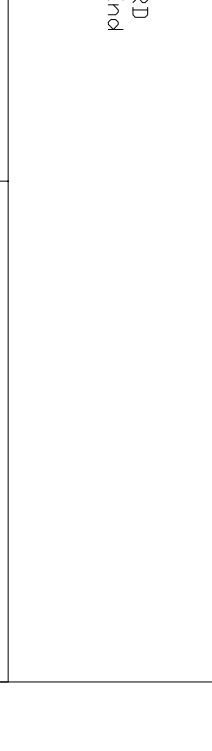
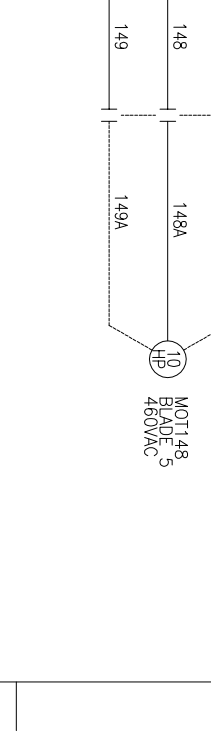
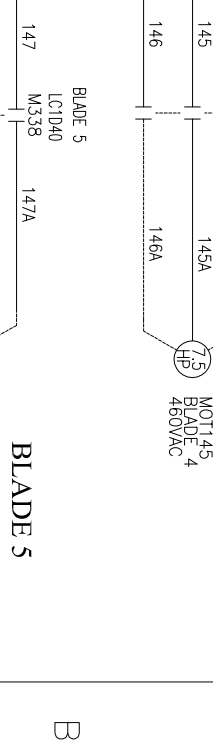
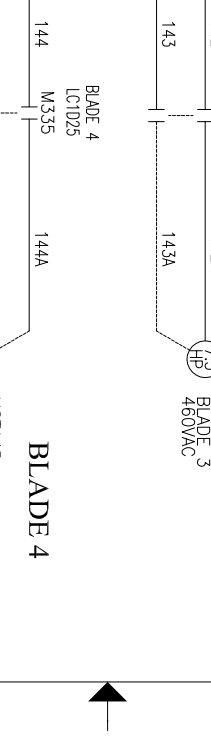
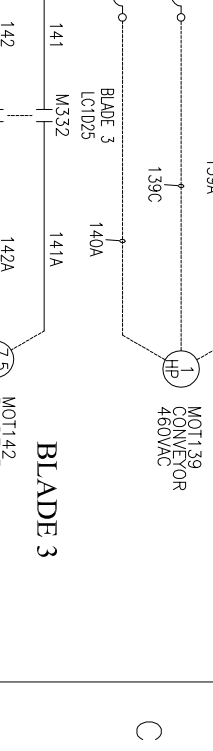
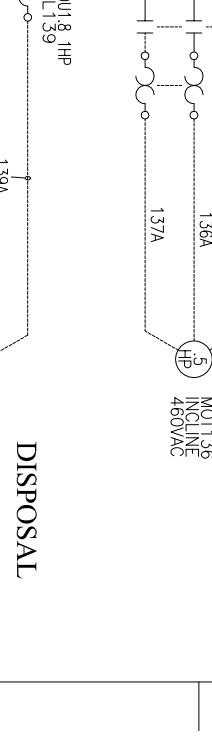
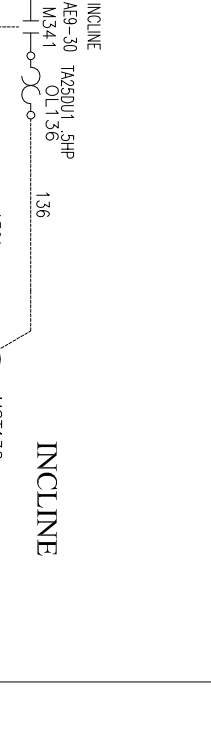
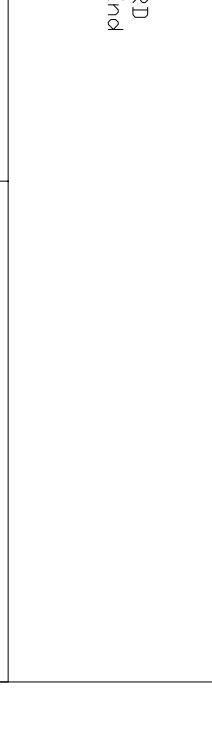
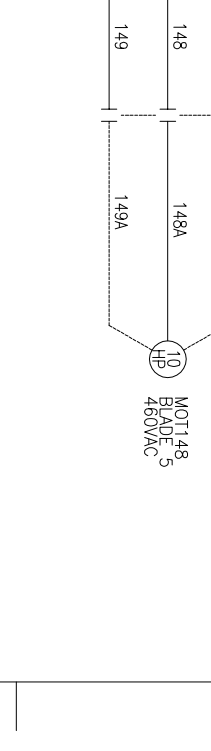
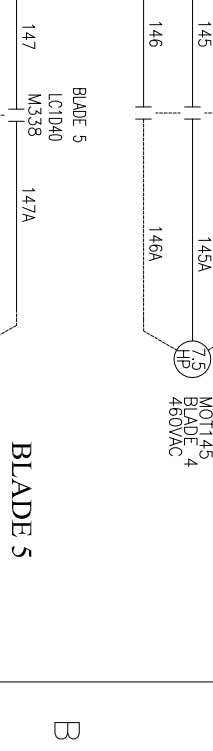
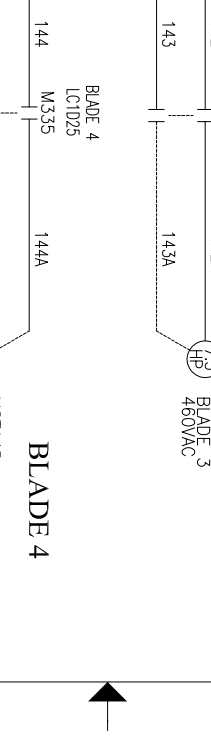
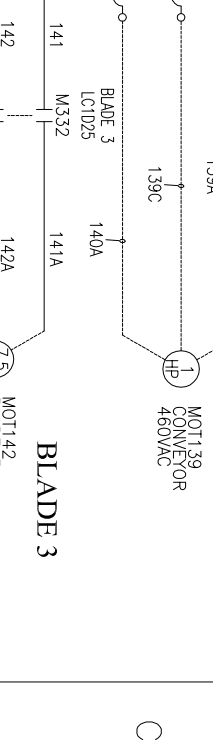
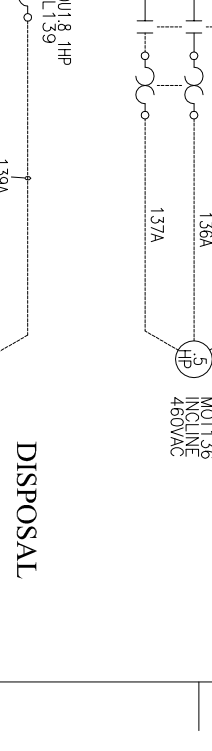
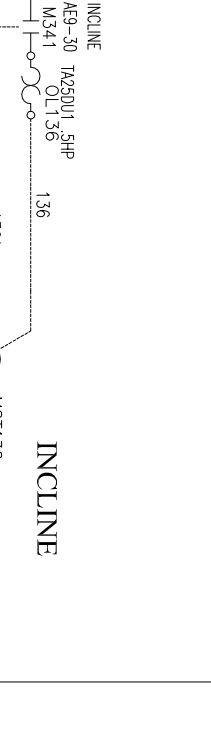
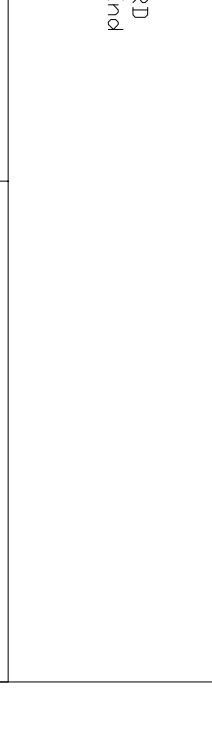
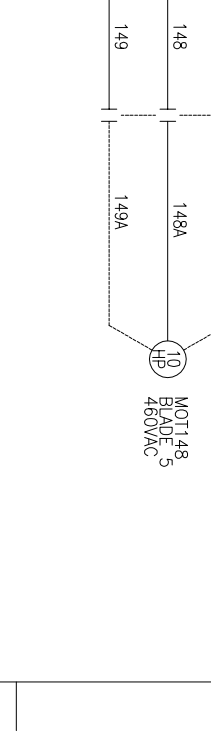
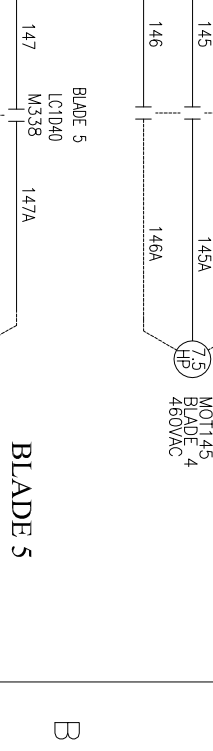
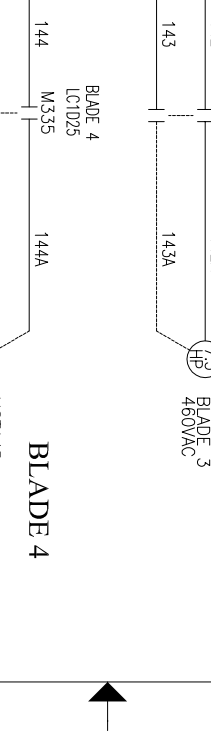
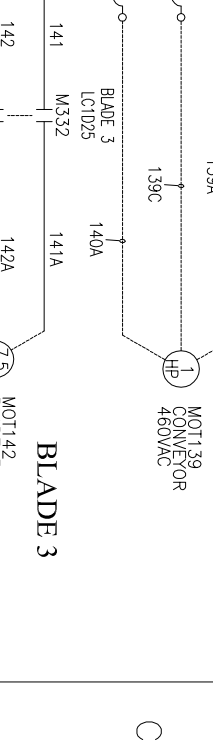
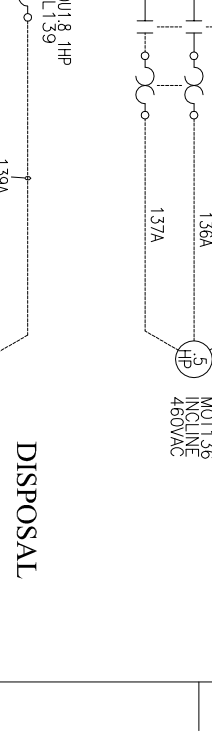
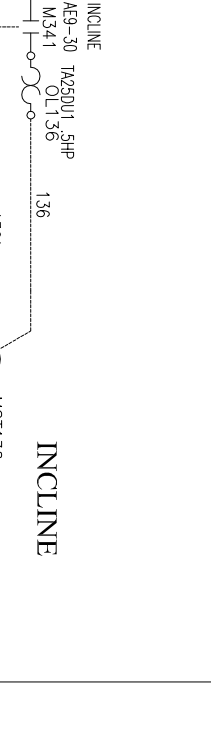
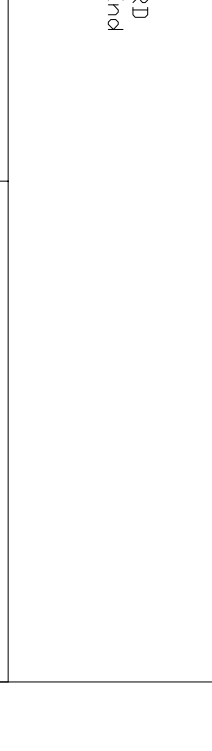
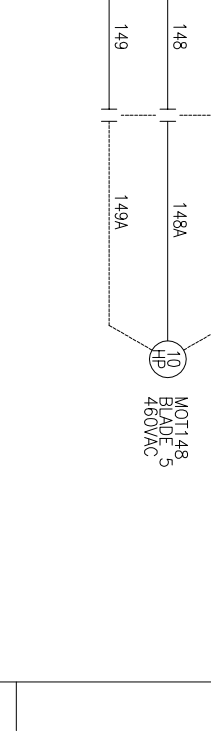
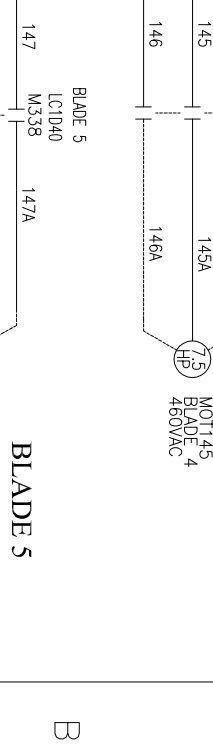
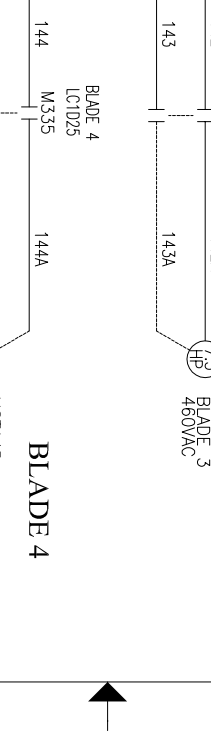
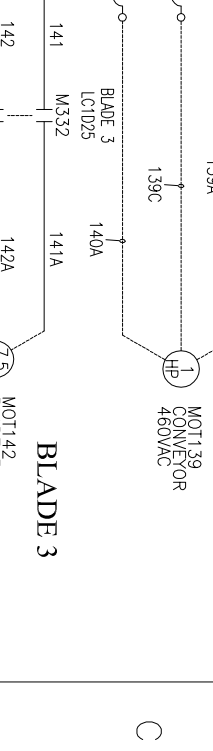
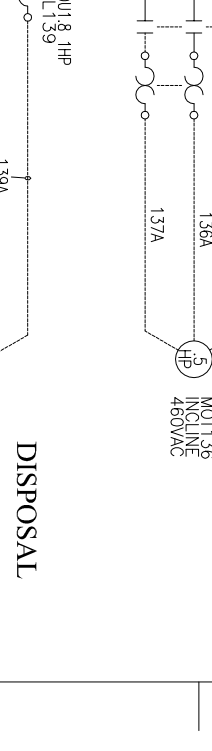
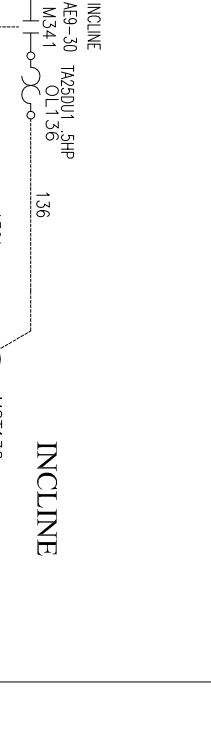
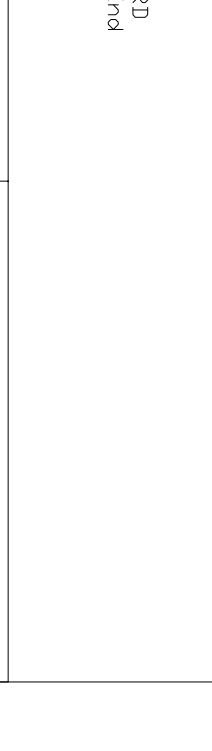
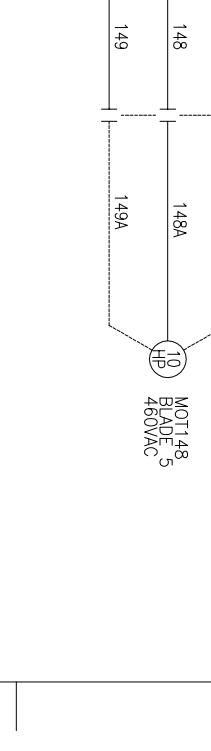
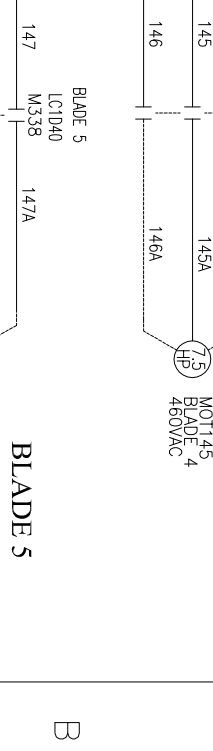
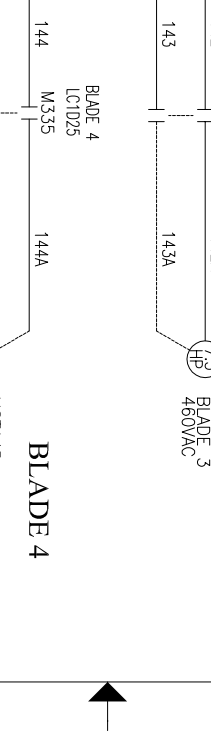
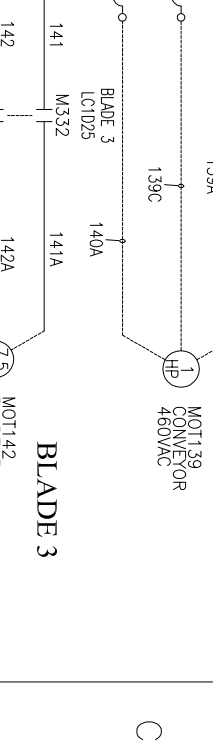
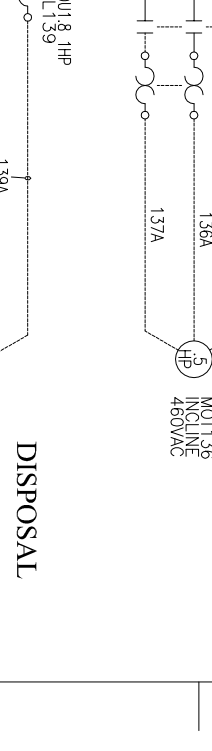
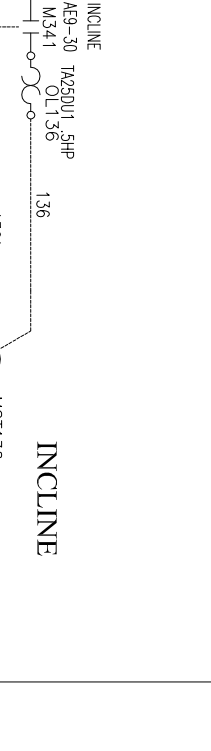
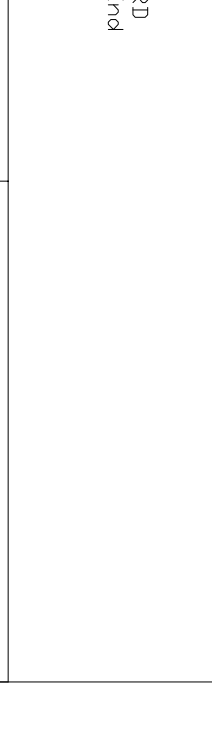
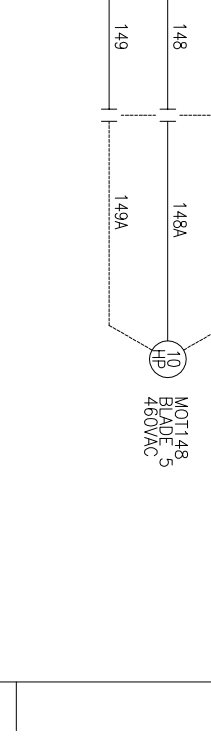
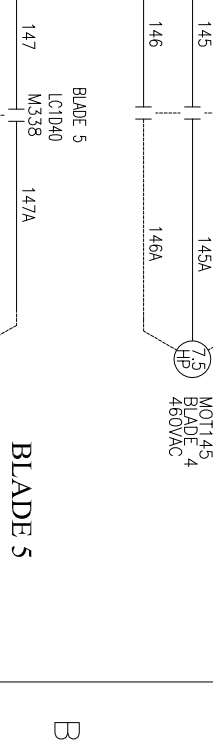
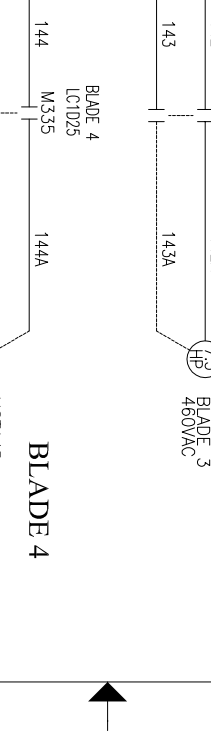
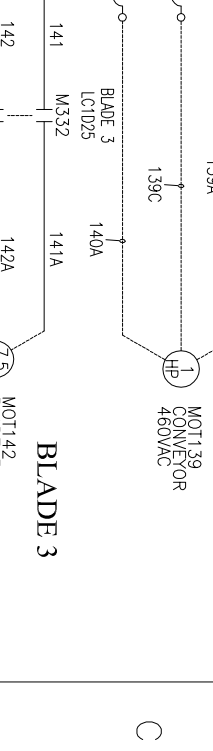
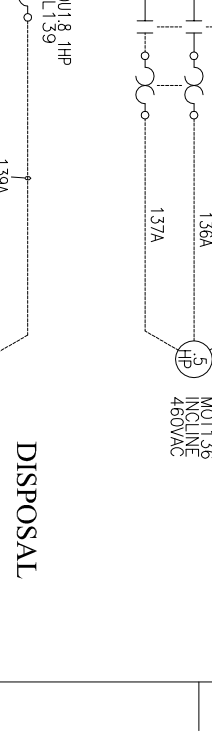
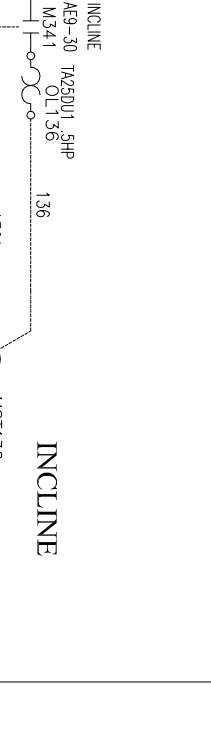
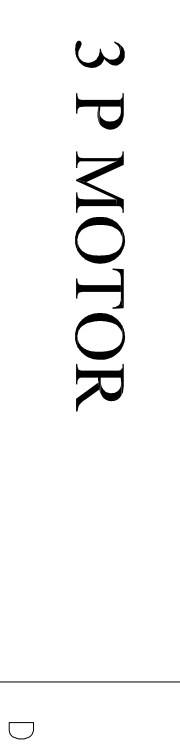
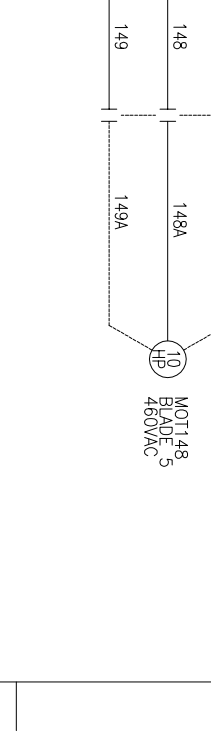
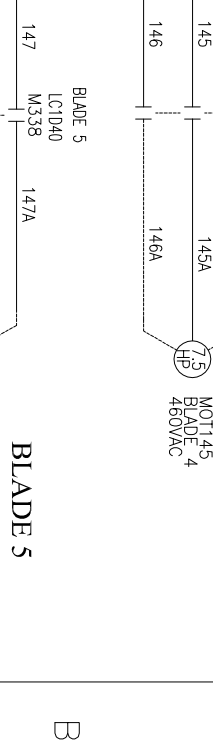
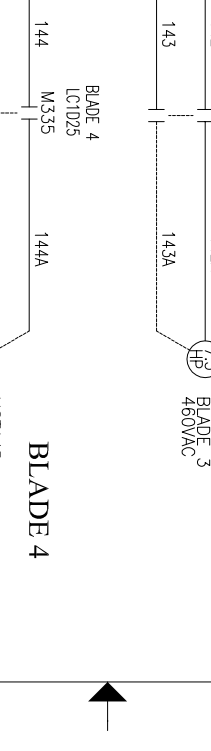
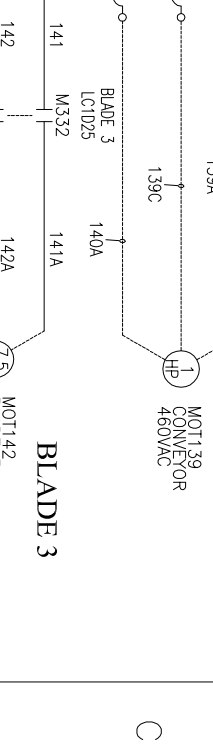
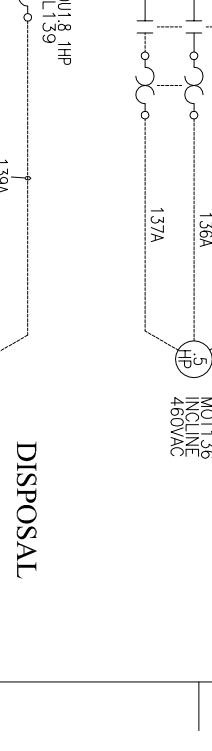
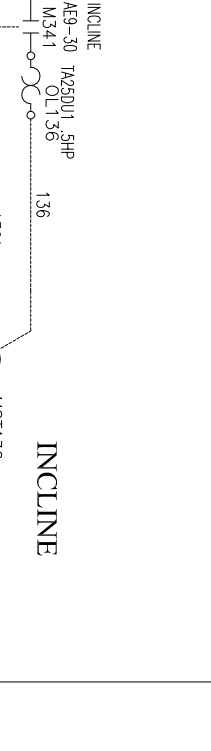
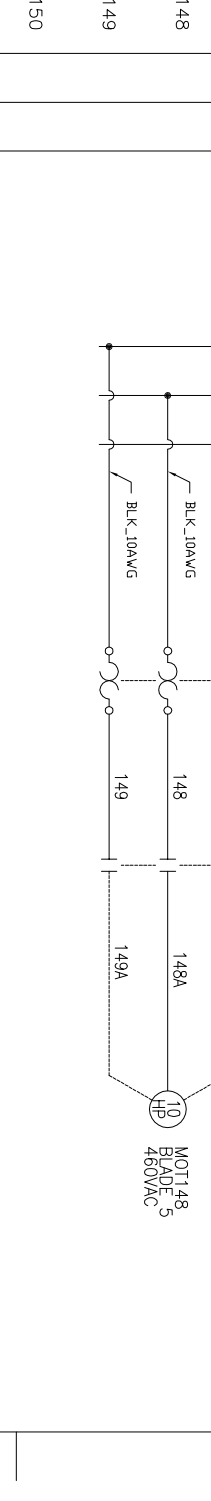
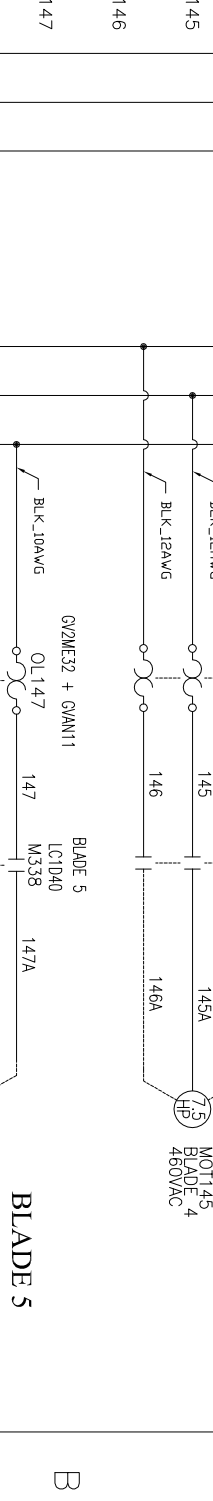
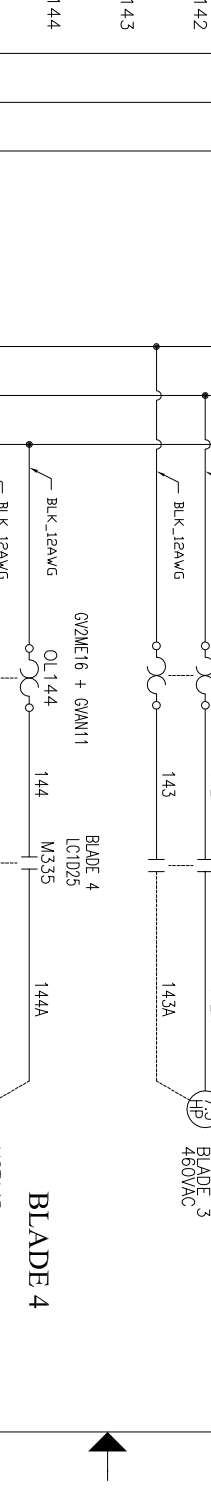
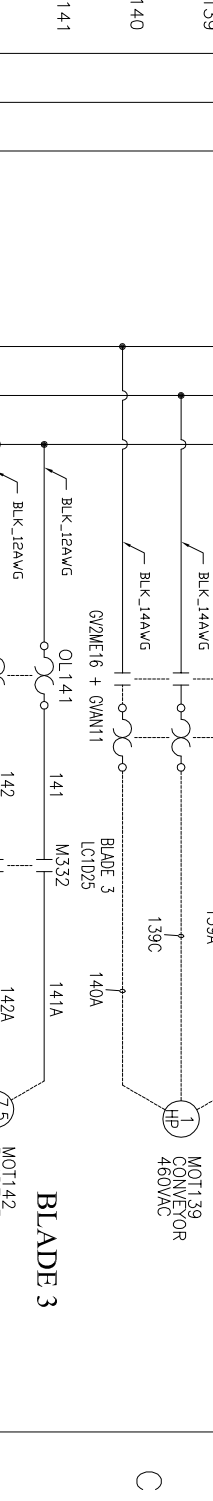
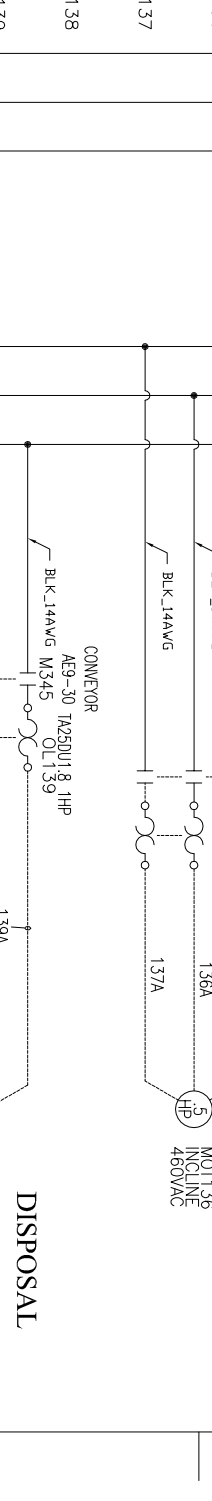
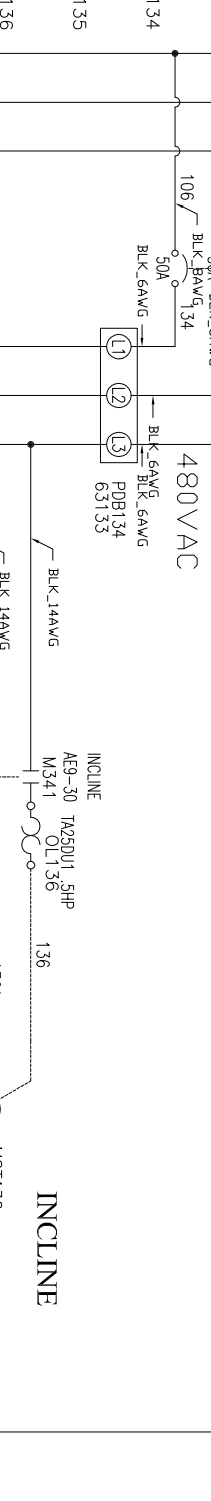
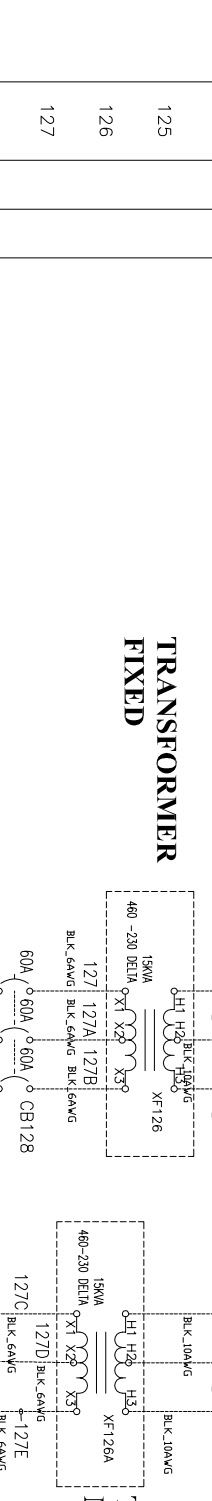
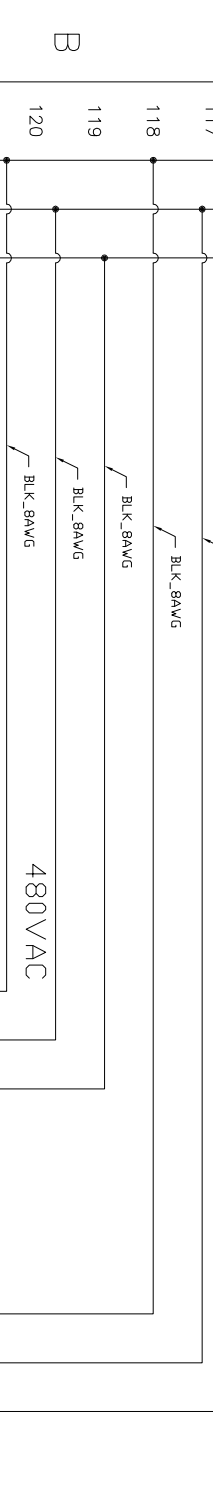
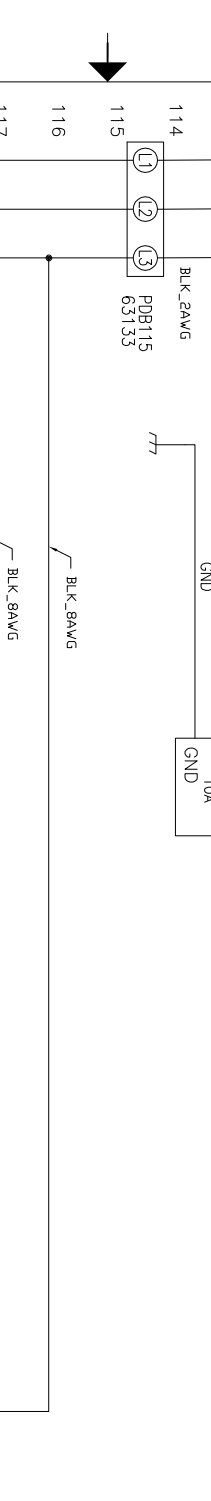
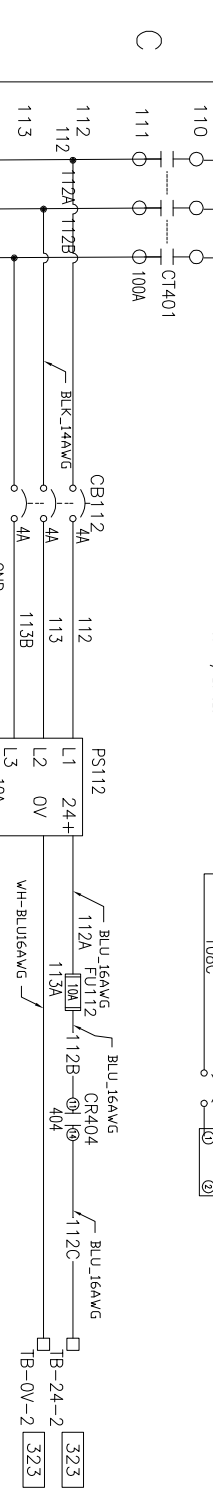
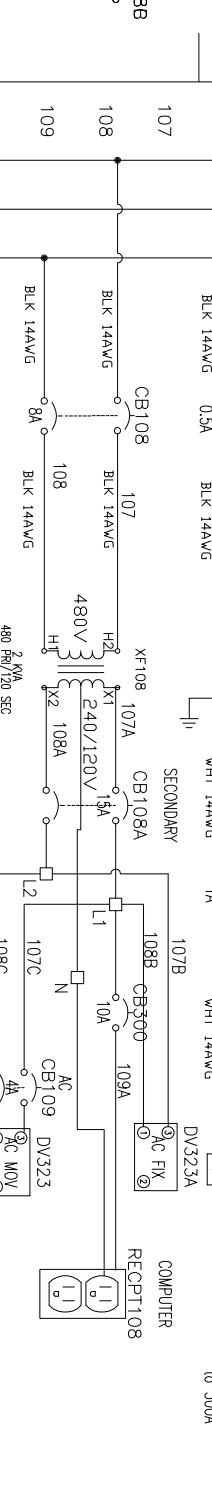
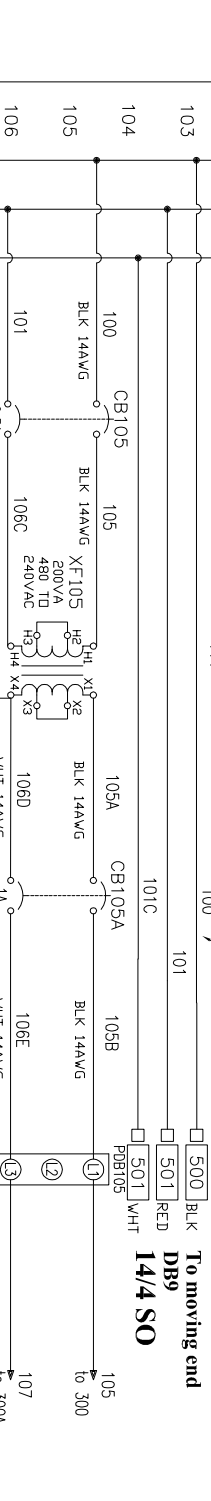
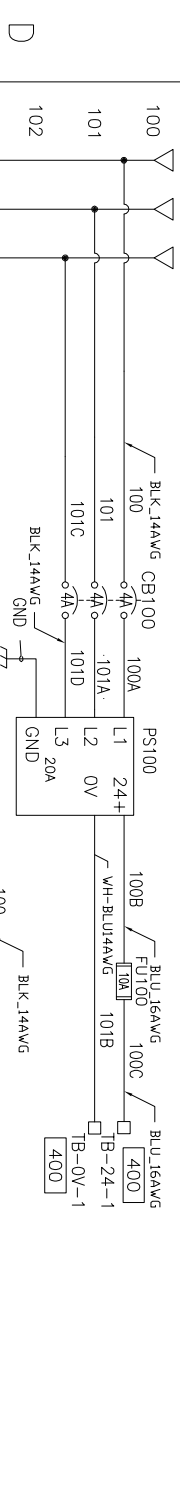
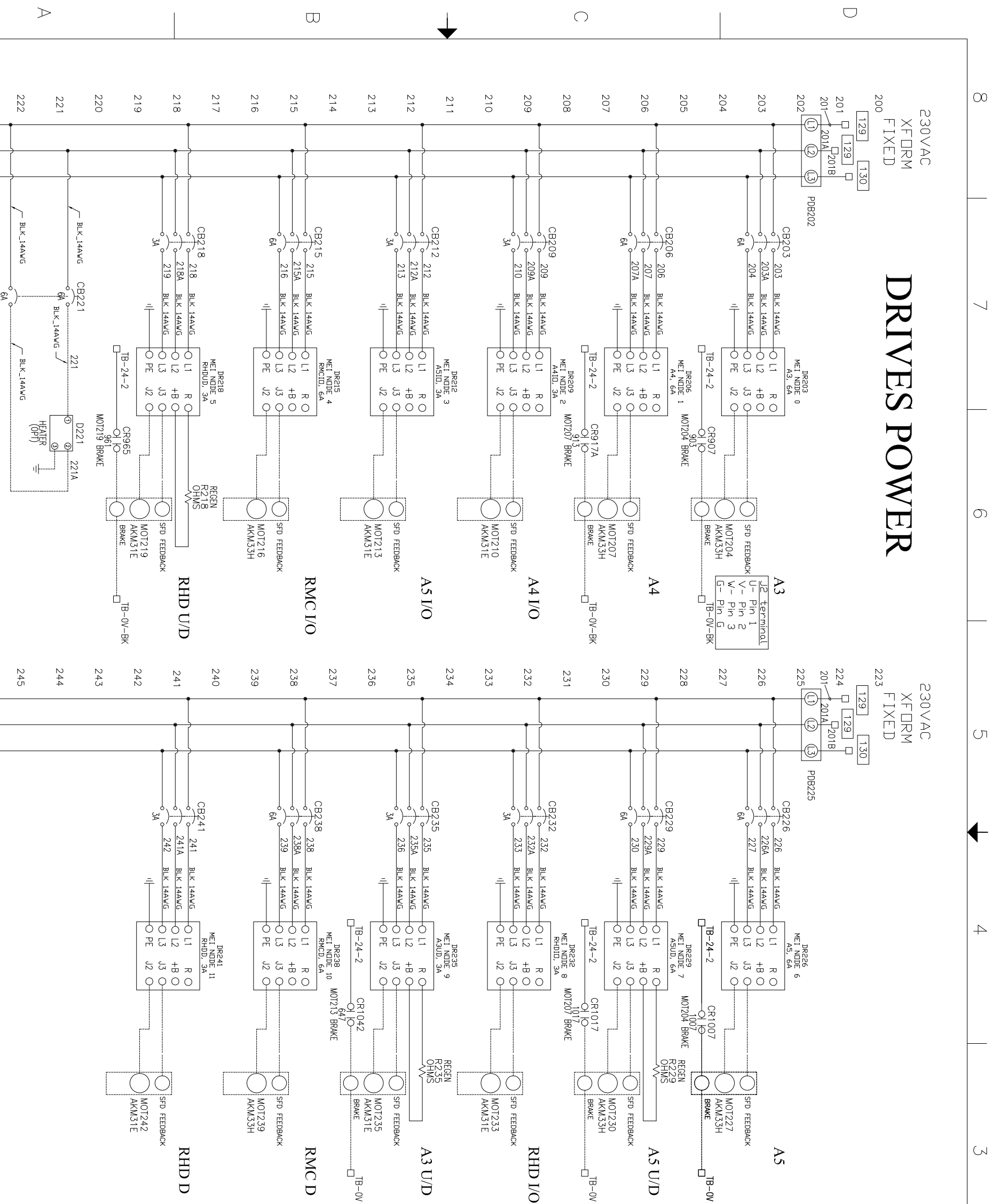

REGIONS

HP-S200 SCHEMATIC

HP Fixed

SIZE	FSCK NO	DRAWING NUMBER	REV
SCALE			E
SHEET	2		

DRIVES CONTROLS

24 VDC -2 CONTROLS

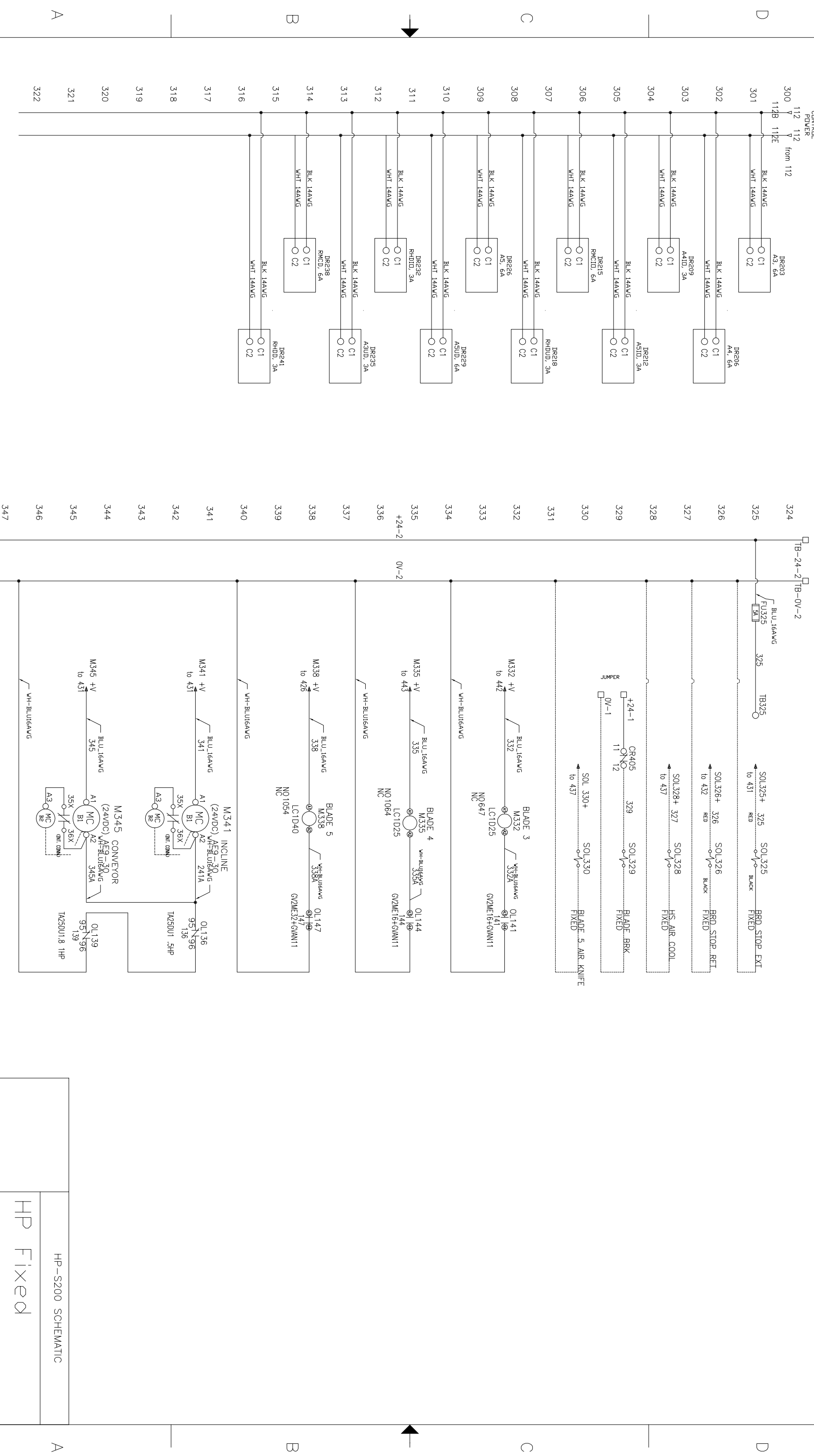

HP-S200 SCHEMATIC

HP Fixed

SIZE	FSCM NO	DRAWING NUMBER	REV
SCALE			E
SHEET			3

E-STOP

SLICE I/O

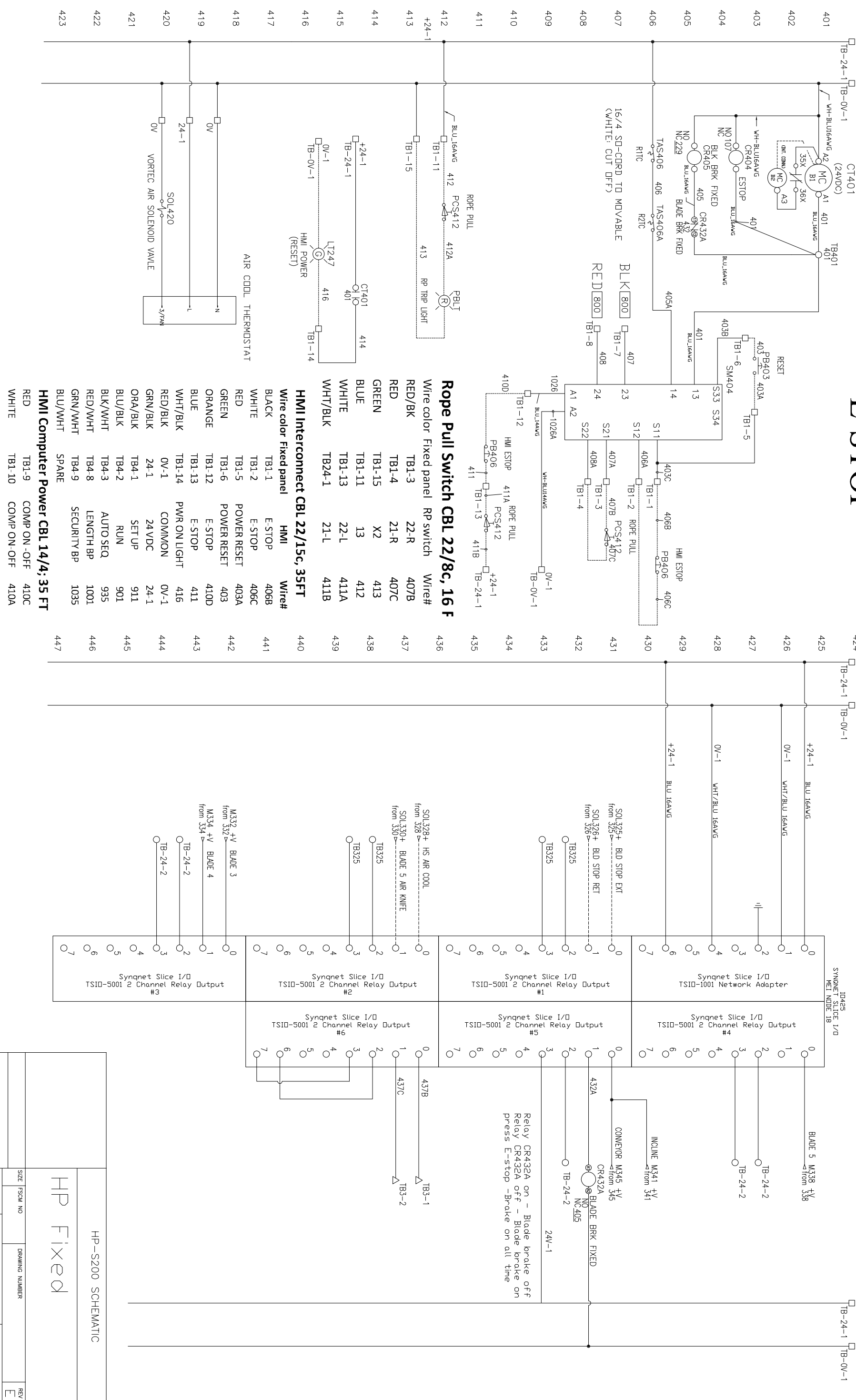

Rope Pull Switch CBL 22/8c, 16 F

Wire color Fixed panel RP switch Wire#

RED/BK	TB1-3	22-R	407B	437
RED	TB1-4	21-R	407C	438
GREEN	TB1-15	X2	413	439
BLUE	TB1-11	13	412	440
WHITE	TB1-13	22-L	411A	441
WHT/BLK	TB24-1	21-L	411B	442

HMI Interconnect CBL 22/15c, 35FT

Wire color Fixed panel HMI Wire#

BLACK	TB1-1	E-STOP	406B	443
WHITE	TB1-2	E-STOP	406C	444
RED	TB1-5	POWER RESET	403A	445
GREEN	TB1-6	POWER RESET	403	446
ORANGE	TB1-12	E-STOP	410D	447
BLUE	TB1-13	E-STOP	411	448
WHT/BLK	TB1-14	PWR ON LIGHT	416	449
RED/BLK	OV-1	COMMON	OV-1	450
GRN/BLK	24-1	24VDC	24-1	451
ORA/BLK	TB4-1	SET UP	911	452
BLU/BLK	TB4-2	RUN	901	453
BLK/WHT	TB4-3	AUTO SEQ	935	454
RED/WHT	TB4-8	LENGTH BP	1001	455
GRN/WHT	TB4-9	SECURITY BP	1035	456
BLU/WHT	SPARE			457

HMI Computer Power CBL 14/4, 35 FT

RED TB1-9 COMP ON - OFF 410C

WHITE TB1-10 COMP ON - OFF 410A

447

446

445

444

443

442

441

440

439

438

437

436

435

434

433

432

431

430

429

428

427

426

425

424

423

422

421

420

419

418

417

416

415

414

413

412

411

410

409

408

407

406

405

404

403

402

401

400

107

105

8

7

6

5

4

3

2

1

A

B

C

D

HP-S200 SCHEMATIC

HP Fixed

SIZE FSCM NO DRAWING NUMBER

SCALE SHEET

REV E

4

1

2

3

4

5

6

7

8

230VAC, 3phase, 60A
XFDRM
MOVING

Disconnect Located External to the Enclosure

DRIVES POWER

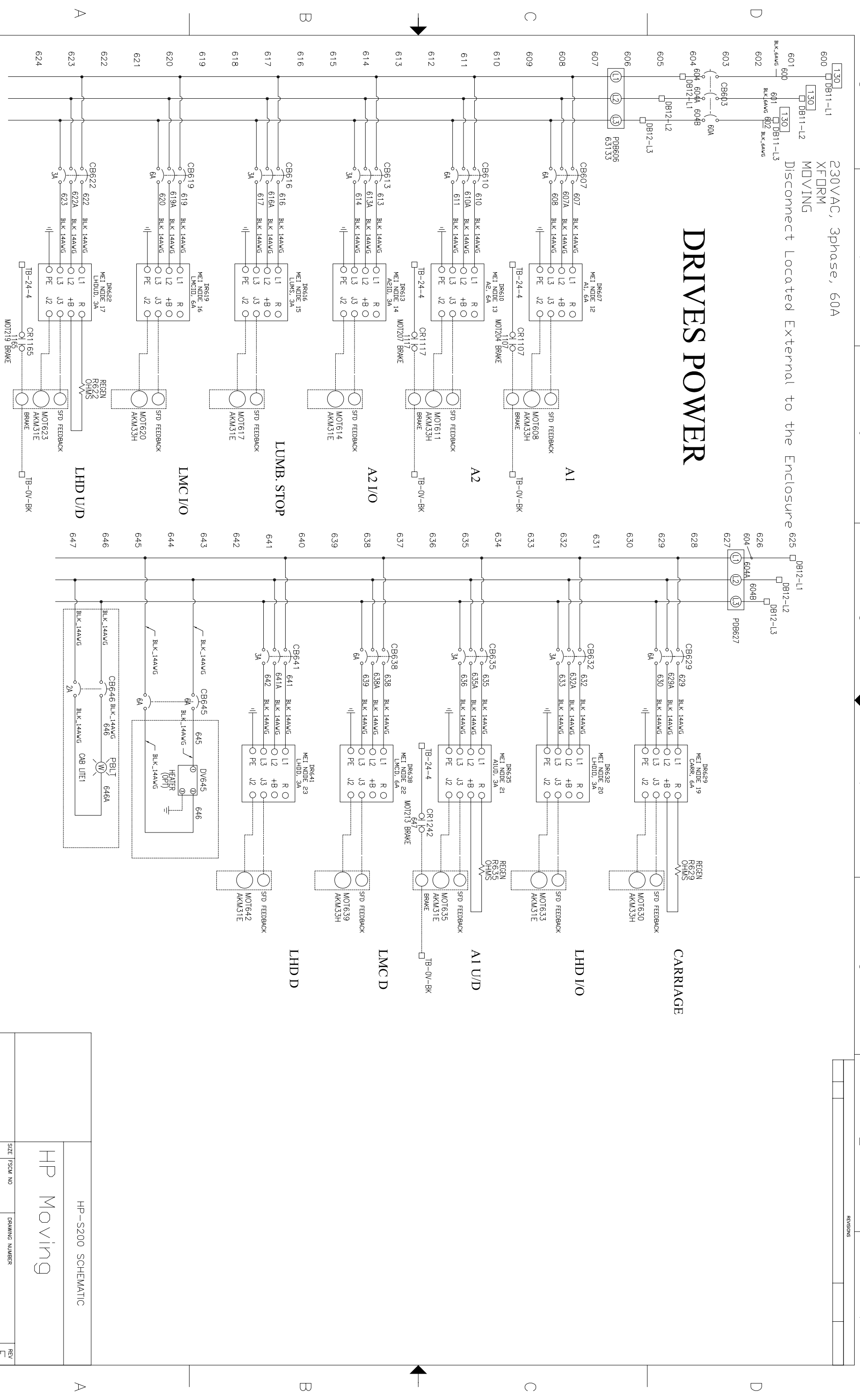

HP-S200 SCHEMATIC
HP Moving

SIZE	FSOM NO	DRAWING NUMBER	REV
SCALE			E
SHEET			6

DRIVES CONTROLS

24 VDC -4 CONTROLS

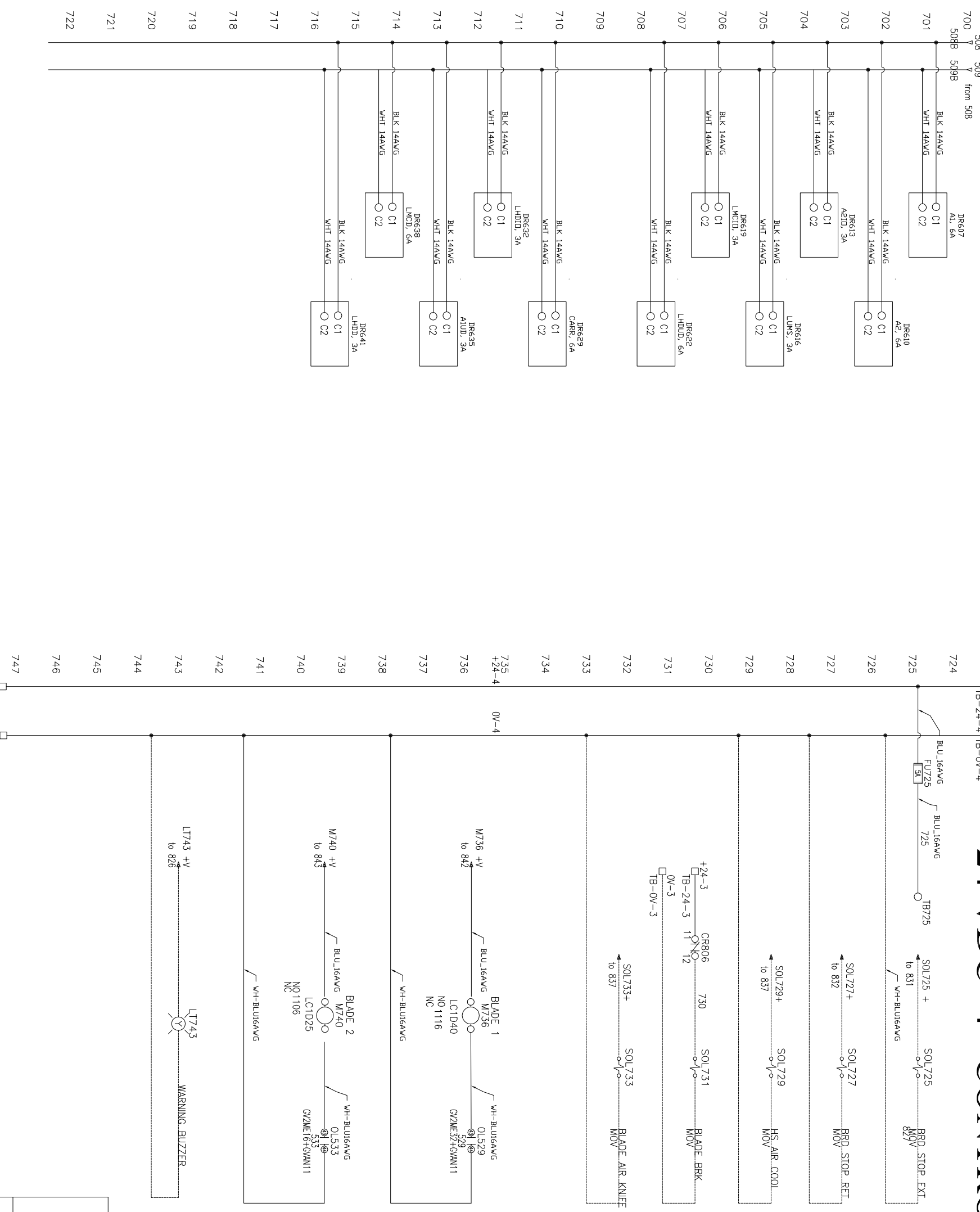

HP-S200 SCHEMATIC
HP Moving

SIZE	FSOM NO	DRAWING NUMBER	REV
SCALE			E
SHEET			7

16/4 FROM
FIXED

SLICE I/O

10925
SYNQNCT SLICE I/O
MEI INDE 24

105 107
TB-24-3 TB-0V-3

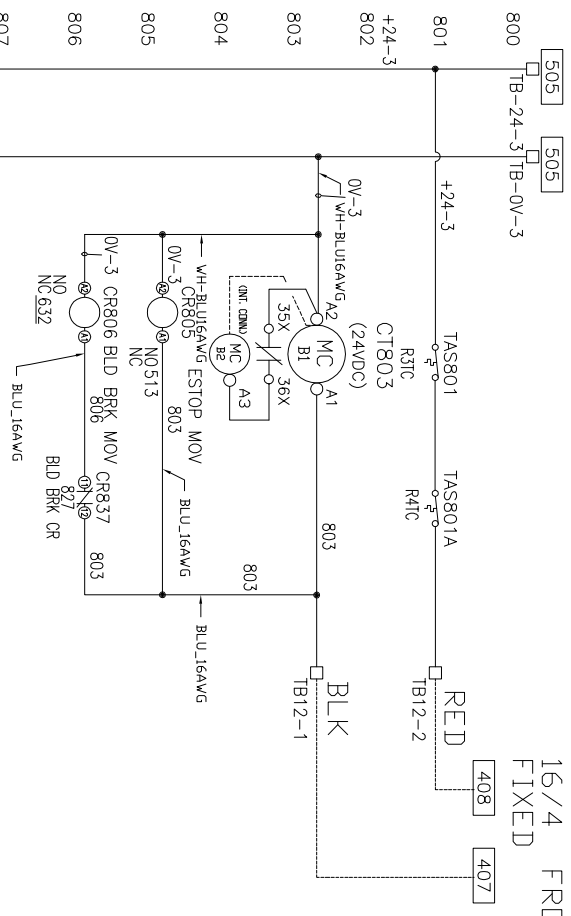

E-STOP

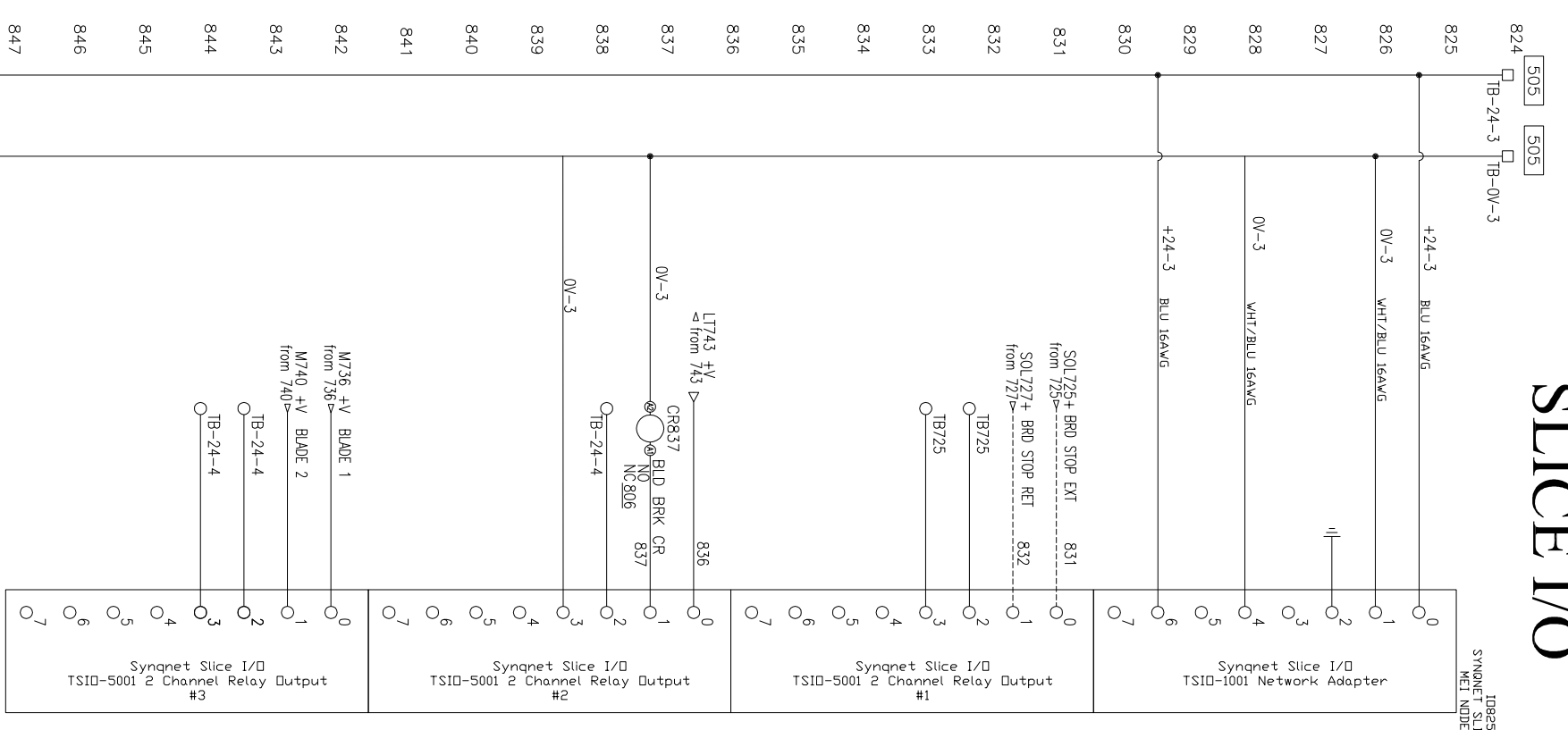

Relay CR837 on - Blade brake off
Relay CR837 off - Blade brake on
press E-stop - Brake on all time

HP-S200 SCHEMATIC
HP Moving

SIZE	FSOM NO	DRAWING NUMBER	REV
SCALE			E
SHEET	8		

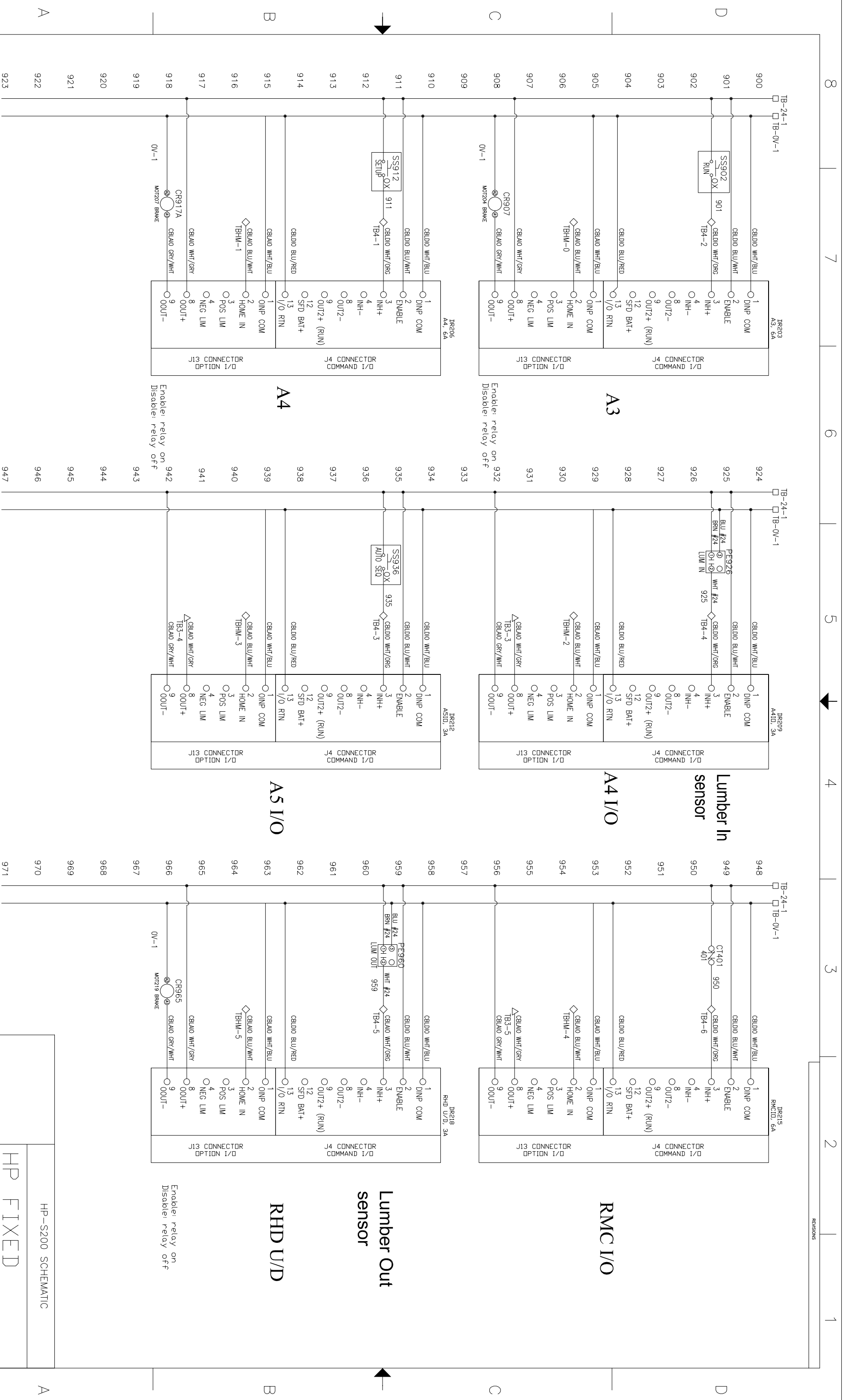

HP-S200 SCHEMATIC

HP FIXED

SIZE	FSCM NO	DRAWING NUMBER	REV
SCALE			E
SHEET			9

8 7 6 5 4 3 2 1

A B C D

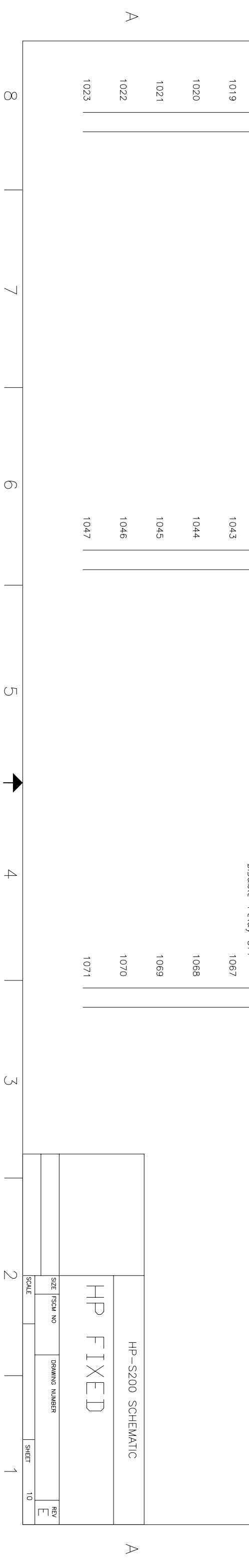
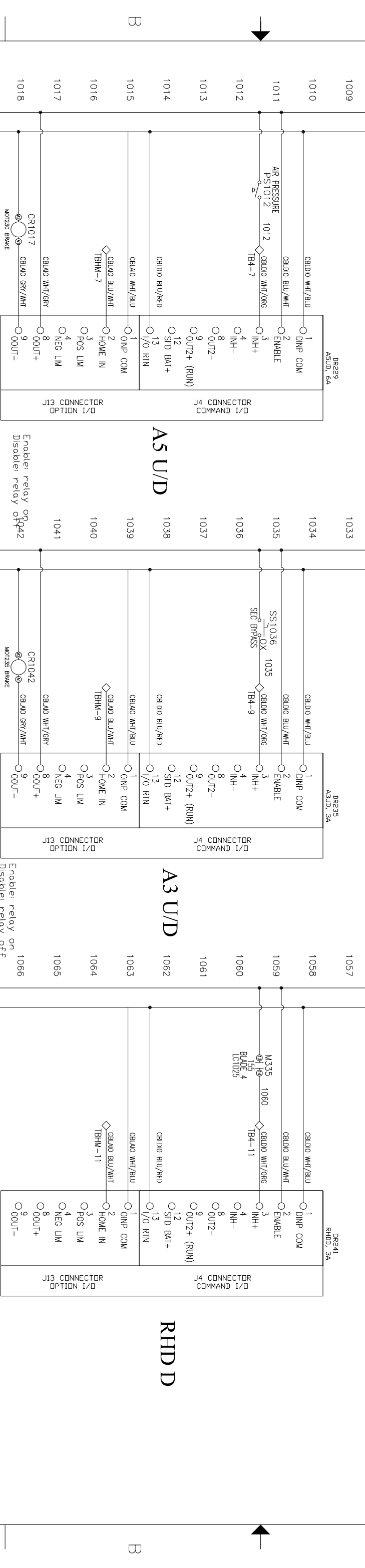
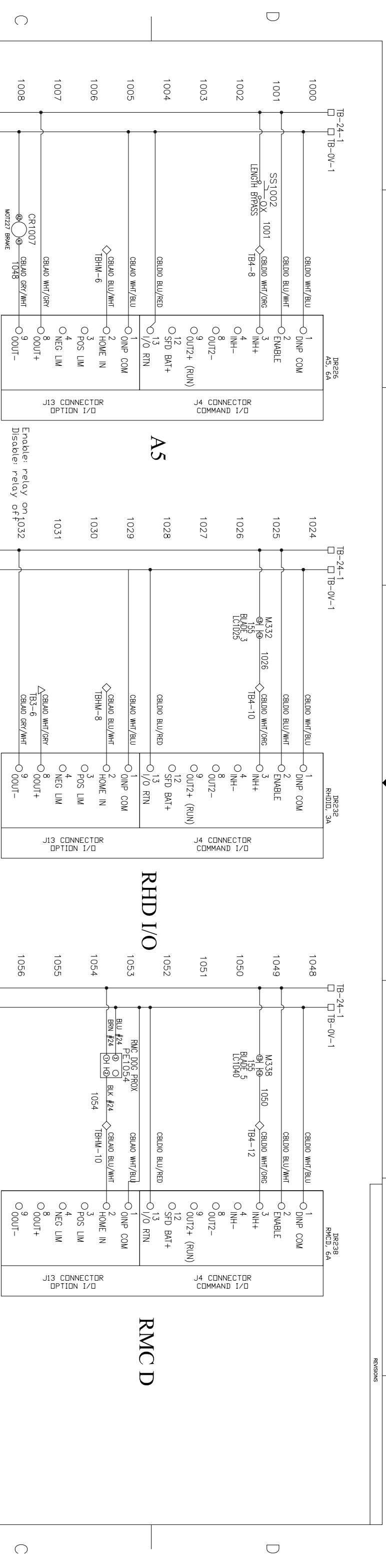

HP-S200 SCHEMATIC

HP FIXED

SIZE	FSCM NO	DRAWING NUMBER	REV
SCALE			E
SHEET			10

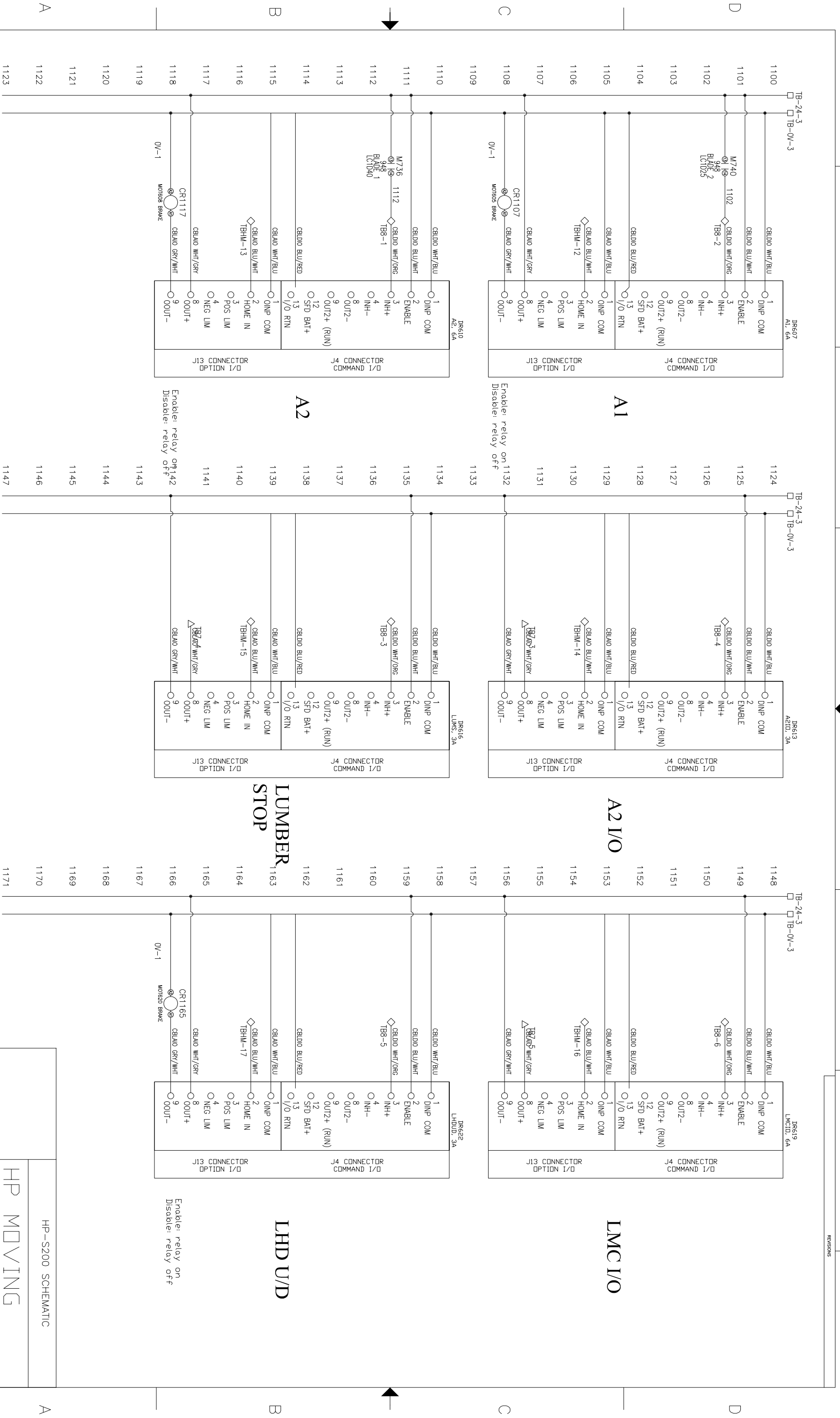

HP-S200 SCHEMATIC
HP MOVING

SIZE	FSCM NO	DRAWING NUMBER	REV
SCALE			E
SHEET			11

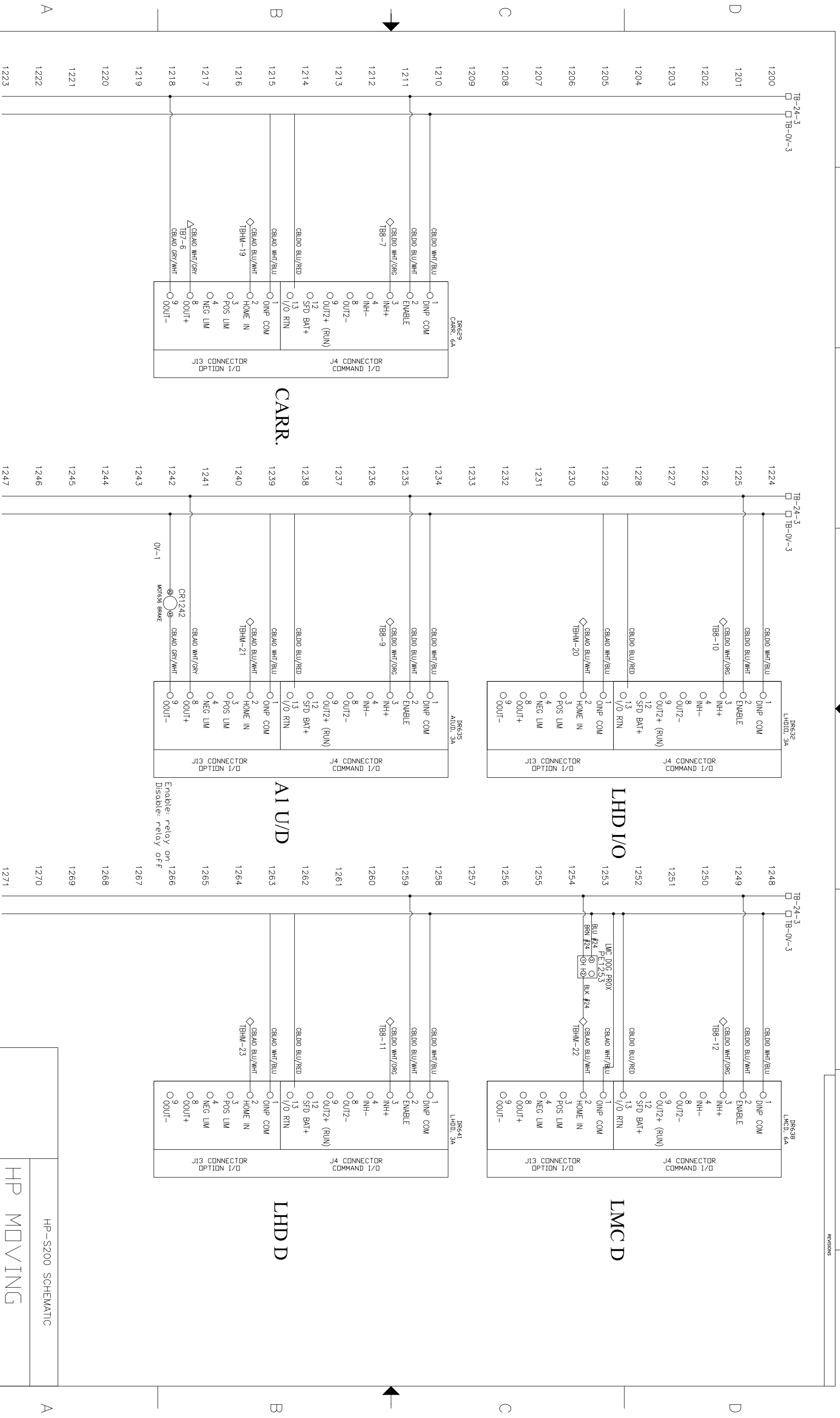

HP-S200 SCHEMATIC

HP MOVING

SIZE	FSCM NO	DRAWING NUMBER	REV
SCALE			E
SHEET			12

● REGEN R235
● REGEN SPARE

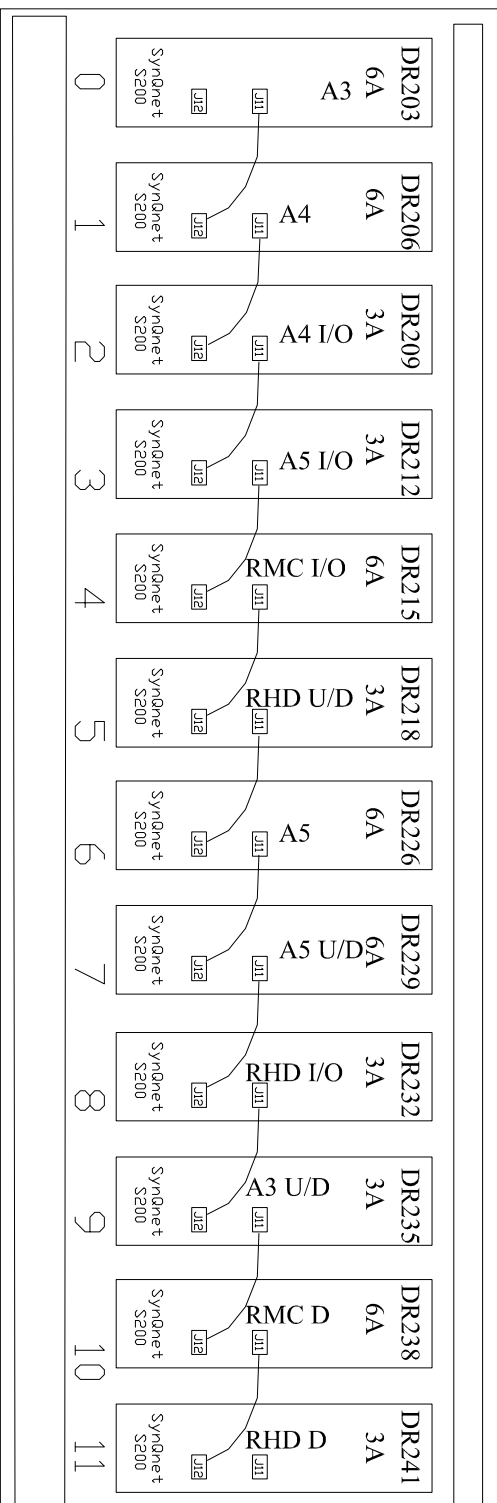
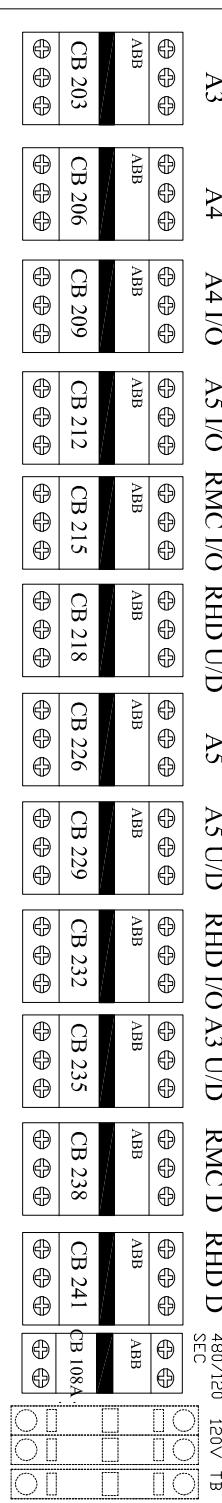
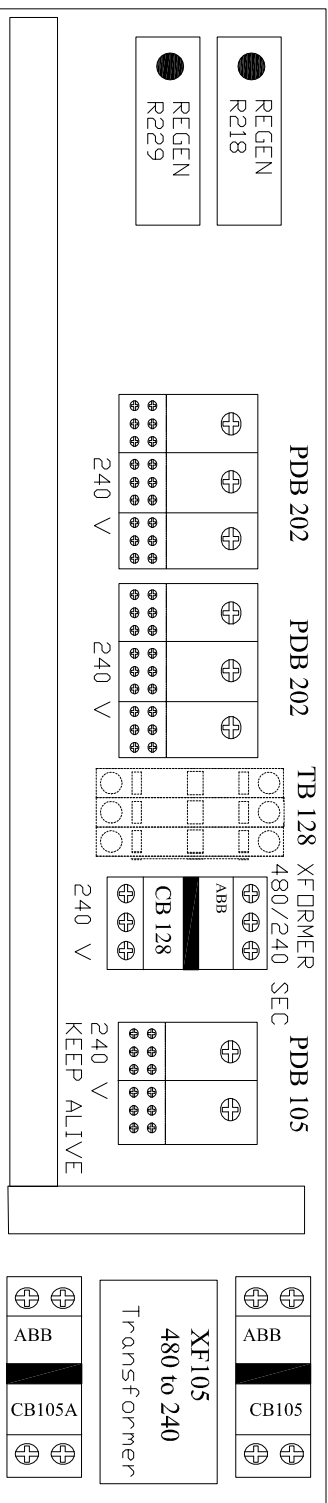

TB ASSY :

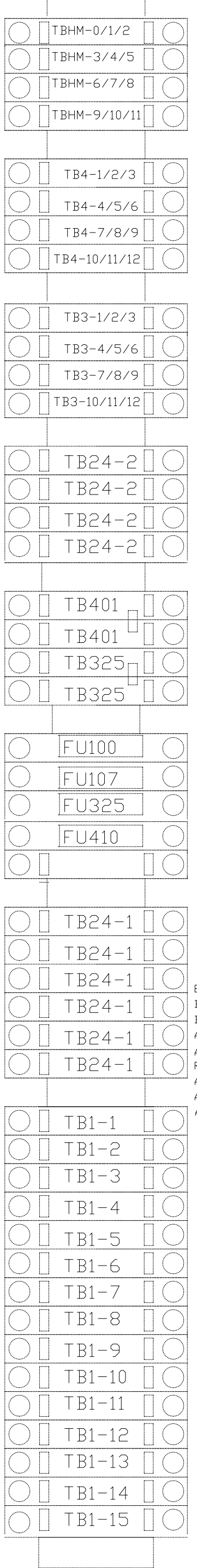

24-1
24-2
COMPUTER

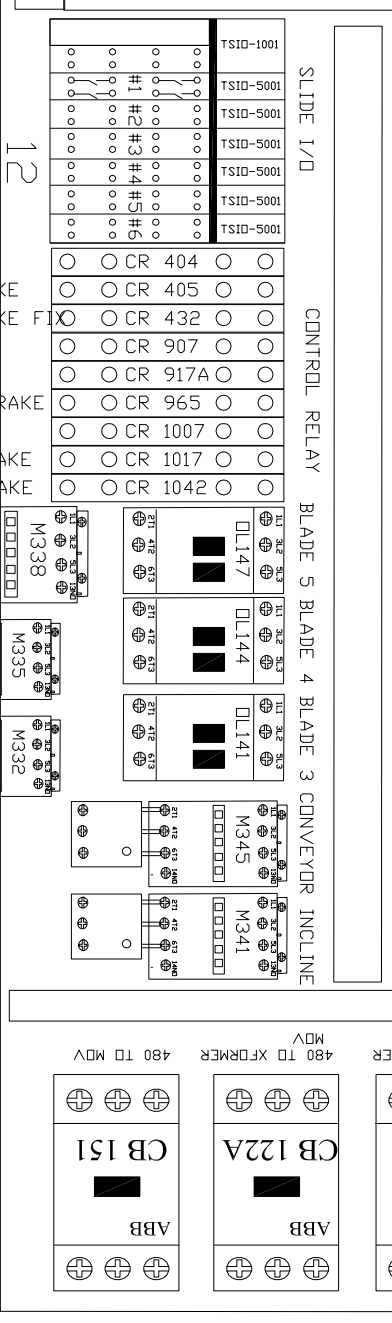
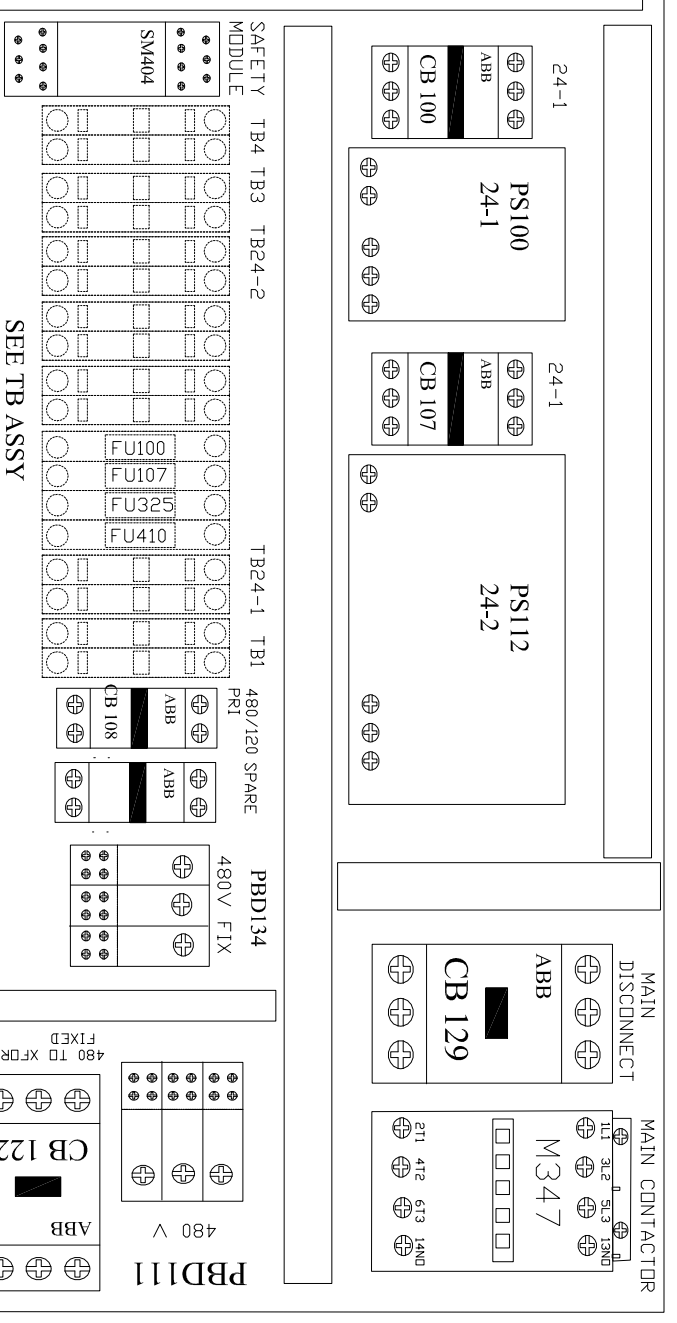

E-STOP
BLADE BRAKE
BLADE BRAKE FIX
A3 BRAKE
A4 BRAKE
RHD U/D BRAKE
A5 BRAKE
A5 U/D BRAKE
A3 U/D BRAKE

HP-S200 SCHEMATIC
HP FIX

SIZE	FSOM NO	DRAWING NUMBER	SHEET	REV
SCALE			11	E

